



ଓଡ଼ିଶା ବିଦ୍ୟୁତ ଶକ୍ତି ସଂଚାରଣ ନିଗମ ଲିଡ.

ODISHA POWER TRANSMISSION CORPORATION LTD.

(A Government of Odisha Undertaking)

CIN – U40102OR2004SGC007553

REGD. OFFICE: JANPATH, BHUBANESWAR – 751022,

OFFICE OF THE DEPUTY GENERAL MANAGER (ELECT.)

EHT (O&M) DIVISION, DHENKANAL

At/Po- Gundichapada, PIN-759025, Dhenkanal (Odisha)

[CIN: U4102OR2004SGC007553](#)

[/ GSTN: 21AAACO7873L1Z6](#)

[Email: ehtm.div.dkl@optcl.co.in](mailto:ehm.div.dkl@optcl.co.in)

TENDER SPECIFICATION

NO.03/2023-2024

FOR

“PCC near both station transformer area, 33kv reserve bus area, cable trench side of 220kv,132kv & 33kv switchyard and Metal spreading near 132/33kv, 20MVA & 40MVA Power Transformer bay at 220/132/33KV Grid S/S, Goda, under EHT (O&M) Division Dhenkanal”

SALE OF TENDER SPECIFICATION: DT. 12-10-2023 (During office hour)

LAST DATE SALE OF TENDER SPECIFICATION: DT. 25-10-2023 (During office hour)

LAST DATE OF SUBMISSION OF TENDER: DT. 26-10-2023 (Up to 1 P.M.)

DATE OF OPENING OF TENDER: DT. 26-10-2023 (at 3.00 P.M.)

COST OF TENDER PAPER: Rs. 2000.00+18%GST extra)
ISSUED TO,

M/S.....

.....

.....

TENDER SPECIFICATION FOR TENDER CALL
NOTICE No. -03/2023-24
of EHT (O&M), DIVISION, DHENKANAL
INDEX

1.	SECTION – I	Instruction to Bidders
2.	SECTION – II	General terms & condition
3.	SECTION – III	Technical Specifications
4.	SECTION – IV	List of Annexures
	ANNEXURE – I	Schedule of Price
	ANNEXURE – II	Technical Specification & Design
	ANNEXURE – III	Detail Data Sheet
5.	COST OF TENDER PAPER (Non-refundable)	Rs. 2000/- + 18%GST=Rs.2360/- (Rupees Two thousand three hundred sixty) only by Cash/ Bank Draft drawn in favour of Deputy General Manager, EHT(O&M) Division, Dhenkanal, payable at SBI, Govindpur Branch, Dhenkanal, Odisha.
6.	SALE OF TENDER PAPER	From 12.10.2023 to Dt. 25.10.2023 . (During office hours) available in the office of the Deputy General Manager (Ele.), EHT (O&M) Division, OPTCL, Dhenkanal.
7.	LAST DATE OF RECEIVING OF TENDER PAPER	Dt.26.10.2023 up to 1.00 PM.
8.	DATE & TIME OF OPENING OF TENDER	Dt. 26.10.2023 at 3.00 P.M.
	Tender posted by the registered post should be reached at:	Odisha Power Transmission Corporation Ltd., Office of the Deputy General Manager, EHT (O&M) Division, Dhenkanal, At/Po- Gundichapada, Dhenkanal-759025, Odisha

INSTRUCTION TO BIDDERS

The Bidders must read in detail the “Instruction to Bidders” and “General terms and conditions” before filling the tender documents.

1. TENDERS:

- A) Bidders must submit their bids with original signature. Only those who have purchased the Tender specification from this office can submit their Tender. Tenders submitted by other will be rejected.
- B) Tender must be submitted in sealed cover subscribed as **“Tender call Notice No. 03/2023-24: “PCC near both station transformer area, 33kv reserve bus area, cable trench side of 220kv,132kv & 33kv switchyard and Metal spreading near 132/33kv, 20MVA & 40MVA Power Transformer bay at 220/132/33KV Grid S/S, Goda, under EHT (O&M) Division Dhenkanal”** on or before **dt.26.10.2023 (01.00PM)** & opening at **03:00PM** on same day and addressed to the **Deputy General Manager, EHT (O&M) Division, Dhenkanal.**
- C) Tender shall be submitted either in person or by registered post & any other means of delivery shall not be accepted. Detailed postal address with PIN No., Phone / Fax/Email of bidder must be mentioned in the application requesting for tender document and on the tender bid. The authority is not responsible for receipt of tender after due date due to postal delay or any other reasons. The tender should be posted by the registry post to reach at **Odisha Power Transmission Corporation Ltd., Office of the Deputy General Manager, EHT (O&M) Division, Dhenkanal, At/Po- Gundichapada, Dhenkanal, Odisha-759025.** Tenders received after due date due to postal delay or any other reason will not be considered. The tenderer who wants to receive the tender paper by post have to deposit additional Rs 100.00 along with the tender paper cost.

2. (i) Bid Documents:-

- (a) Tender Papers-01 Set (all pages signed by bidder)**
(b) Money receipt of Tender paper Purchased (original & a Photocopy)
(c) Self attested Photocopy of PAN-01no
(d) Self attested Photocopy of GST-01no
(e) Valid “C or D” class civil license.

Bid Documents are compulsory otherwise bid will be treated as cancelled.

(ii) Experience: - The bidders may submit a copy of past experience if any regarding supply of similar materials to GRIDCO/ OPTCL or any other state or central PSUs/Govt.

4. INFORMATION ON COMPETITORS:

Bidders have right to know information on competitors only at the time of opening of the bids. No further information on competitors shall be provided at any other point / stage of the tender without prejudice to Right to Information Act – 2005.

5. OPENING OF TENDERS:

A. Copy of PAN card/ GSTIN/ GST certificate & valid civil license & labor contract license must be enclosed with the tender bids.

B. Bidders themselves or their authorized representatives (possessing authorization letter in original) shall be allowed to attend opening event of the tenders.

6. RIGHT TO REJECT /ACCEPT ANY TENDER:

The authority reserves the right either to reject or to accept any or all tenders if the situation so warrants in the interest of the department. Orders may also be split up between different Tenderers on individual merits of the Tenderer. The authority has exclusive right to alter the order at the time of placing final work order. It may be clearly understood by the Tenderer that the authority need not assign any reason for any of the above action[s].

7. EVALUATION OF PRICE BIDS:

Order on the firm will be placed on the basis of L1 evaluated price of the techno-commercial qualified bidders. However OPTCL reserves the right to split up the orders among bidders on individual merits of the bidders, if the situation so warrants, in the interest of OPTCL. All the bidders may be required to explain / justify the basis of their quoted rates as and when asked for. In case, any bidder fails to justify his quoted rates or refuses to co-operate in this regard, they will not be considered for participating in the tendering process and will not be allowed to participate in any future tender for a period of (3) three years.

8. Tender should be prepared clearly and without any overwriting and corrections. Erasures and other changes shall bear the dated initial of the person signing the Tender.
9. In the event of discrepancy or arithmetical error in the schedule of price, the decision of the authority shall be final and binding on the tenderer. For evaluation, the price mentioned in words shall be taken if there is any difference in figure and word in the price bid.

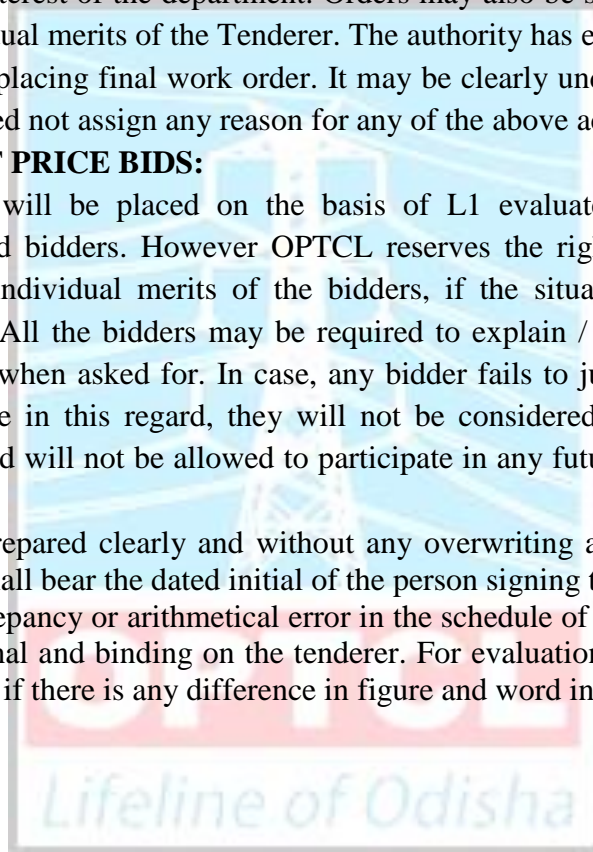

GENERAL TERMS AND CONDITIONS

1. **Validity:** Tenderers are requested to keep the validity of their offer for a period of 03 months from the date of opening of tender.
2. **Price:** The bidders are advised to quote their rate as per the price schedule in **Annexure-I, Section IV**. The unit rate and the total amount should be entered in figures and words. Any correction should be attested under the seal of the Firm/ Contractor. In case of any difference between figure and words in the price schedule the price mentioned in words should be taken into consideration for evaluation.
3. **Taxes:** Taxes, if any shall be mentioned extra.
4. **Terms of Payment:** 100% payment with taxes etc shall be made after completion of work and due verification thereof by the consignee and approval of Guarantee Certificate from the competent authority. The bills in triplicate should be submitted to the paying officer along with completion report duly verified by the concerned inspecting officer.
5. **Completion of Work:** The work should be completed within 30 days from the date of order. If the work could not be completed within scheduled date due to any valid reason, then completion period may be extended on written request by the Bidder. If the work will not commence & complete within the stipulated period, then the penalty should be imposed as per clause No.06 of SECTION-II. order shall be liable for cancellation with forfeiture of Earnest money/ Security Deposit.
6. **Penalty:** Penalty @ ½ % (half per cent) per week up to a maximum of 5% of the total value of the work order will be imposed and recovered from dues admissible if the work is not completed within the scheduled period.
7. **Extension of time:** If the work is delayed due to reason beyond the control of agency, the agency shall without delay give justification. The authority on receipt of such notice may agree to extend the contract due date if reasonable but without prejudice to other terms and conditions of this contract.
8. **Earnest Money Deposit:** The bidder is to deposit EMD @Rs 5000/- in shape of cash/ bank draft drawn in favour of **Deputy General Manager, EHT (O&M) Division, Dhenkanal, payable at SBI, Govindpur Branch, Dhenkanal**. The EMD of successful tenderers will be refunded after deposit of security-cum performance deposit. The EMD of all unsuccessful tenderers shall be refunded on written request after finalization of tender. No interest shall be paid on EMD. No adjustment towards EMD shall be permitted against outstanding amount, if any, remain with the OPTCL.
9. **Security Deposit:** The tenderers whose offer qualifies for acceptance will be awarded Work Order and the contractor shall have to deposit Security-cum-performance guarantee equal to **10% (Ten percent)** of contract value in shape of Bank Draft in favour of **Deputy General Manager, EHT (O&M) Division, Dhenkanal, payable at SBI, Govindpur Branch, Dhenkanal**. **If the security deposit is not submitted, 10% of the contract value will be deducted from the bill.** The Security deposit will be released after two months of completion of the guarantee period subject to fulfillment of guarantee stated under clause-10 on a receipt of application for this purpose. No interest shall be paid to the agency

towards the security deposit so deposited by the agency. **If Security Deposit not claimed for refund within a period of three years after completion of work, it will be forfeited.**

- 10. Guarantee:** The work covered under this contract should be guaranteed for satisfactory performance for a period of 12 months from the date of completion of work. In case of any defects noticed during this period, the same shall be replaced / rectified by the contractor free of cost provided such defects are due to fault design / bad workmanship or bad materials used upon written notice from the engineer-in-charge. The replaced material/rectified work should also have similar guarantee. The above guarantee certificate shall be furnished in triplicate to the undersigned for approval. In the event of any breach on default in all or any condition of order, Security Deposit will be forfeited.
- 11. Workmen's Compensation:** The contractor shall be fully responsible for paying compensation, if any under the workmen compensation act on account of workmen deployed by him. The Authority reserves the right to reject the notice/ award the contract among any responsive bidders against this tender or without assigning any reason thereof. All other terms and conditions will be governed by OPTCL as per Rules.
- 12. Consignee:** The **SDO, 220/132/33KV Grid S/S Goda** is the consignee & verifying officer for the work.
- 13. Paying Officer:** The **DGM, EHT (O&M) Division, Dhenkanal** is the paying officer for this contract.
- 14. Jurisdiction of Court:** Dispute if any, arising against the work order issued to the contractor shall be filed by either party in any court of law to which the jurisdiction of Odisha High Court extends.

The Authority reserves the right to reject the notice/ award the contract among any responsive bidders against this tender or without assigning any reason thereof. All other terms and conditions will be governed by OPTCL as per Rules.

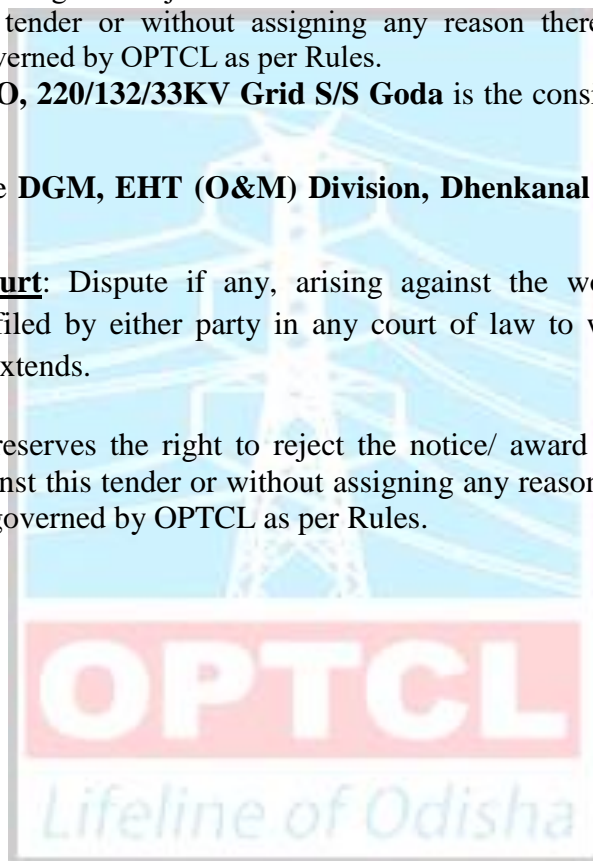

A. TECHNICAL SPECIFICATIONS

The Scope of work: - The scope of works must covers the followings & as per Drawing.

Details of PCC near both station transformer area, 33kv reserve bus area, cable trench side of 220kv, 132kv & 33kv switchyard and Metal spreading near 132/33kv, 20MVA & 40MVA Power Transformer bay at 220/132/33KV Grid S/S, Goda, under EHT (O&M) Division Dhenkanal.

Sl. No.	Description of Items (As per Technical Specification)	Unit	Quantity
1	Earth work in hard soil or gravelly soil within 50m, initial lead and 1.5m, initial lift including rough dressing and breaking clods to maximum 5cm to 7cm and laying in layers not exceeding 0.3m in depth and as per direction of the Engineer-in-charge. This also includes excavation in all type of soils or rocks, back filling and disposal of excess earth or rocks to make the area to a level for construction as per scope and as per approved drawing and specification. Excavation upto 0.125 mm depth = 687.3Sqm X 0.125 Mtr = 85.91 Cum	Cum	85.91
2	Supply and spreading of sand of loose, fine, clear, good quality river sand, including stacking for measurement with providing and supplying all labour, material, equipment etc. required for proper levelling with water sprinkling. 687.3 Sqm X 0.05 mtr = 34.36 Cum	Cum	34.36
3	PCC : Spreading of plain cement concert with supply of good quality 20 mm machine broken granite chips, good quality river sand mixing ratio 1:3:6, concreting and maintaining proper sloping for easy discharge of storm water having concrete thickness of 75 mm. including rolling , dressing, compacting, the area and curing. As per technical specification and approved drawing, and as per the instruction of the Engg-in-Charge. 687.3 Sqm X 0.075 mtr = 51.54 cum	Cum	51.54
4	Supply and spreading of hard granite stone of 20mm metal, including stacking upto a depth of 75mm thickness. (379.88-74.91=304.97) 304.97 Sqm X 0.075 mtr = 22.87 cum	Cum	22.87

B. DRAWING

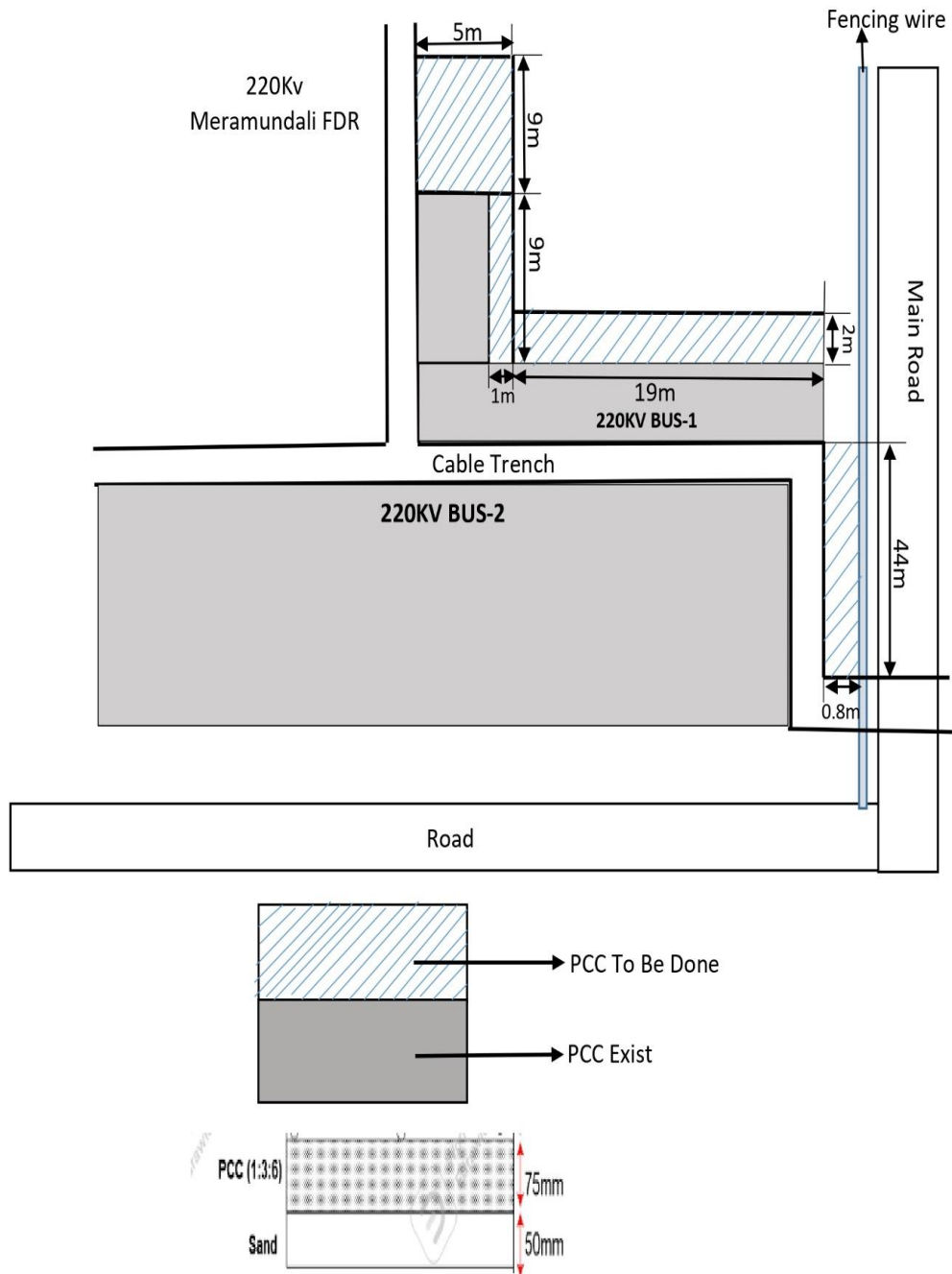

Fig-I (220kV Side Switchyard)

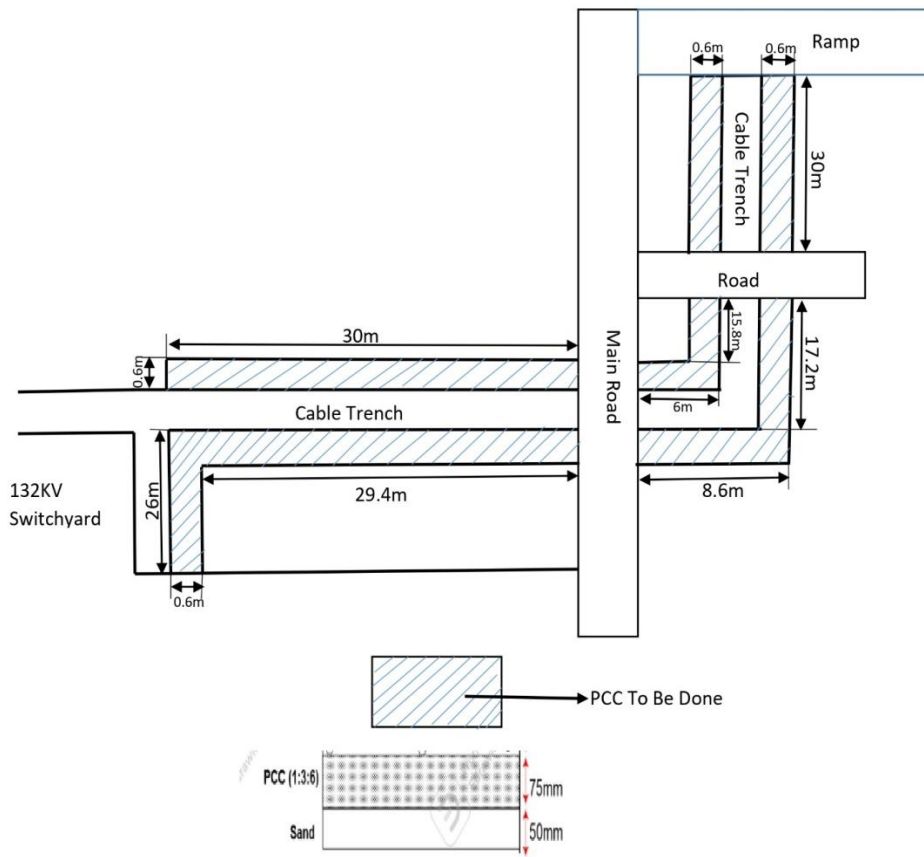

Fig-II (132kV Side Switchyard)

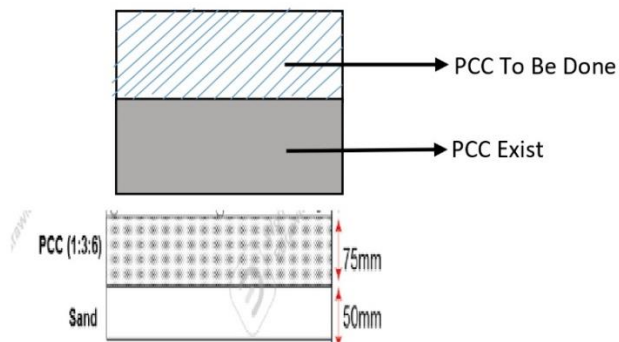
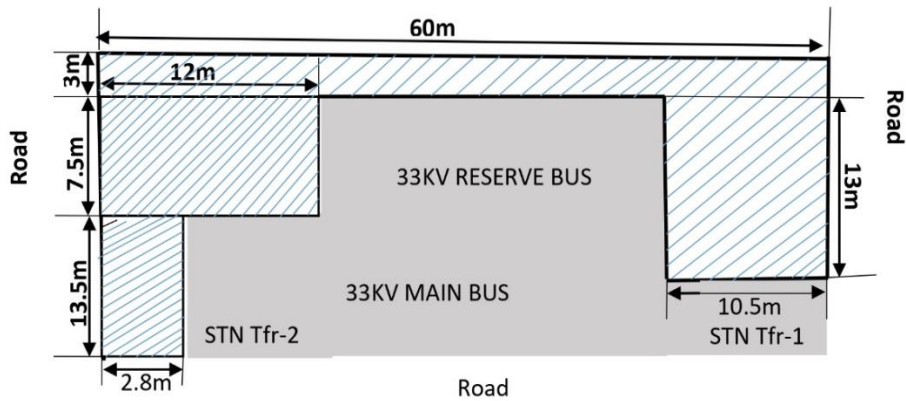
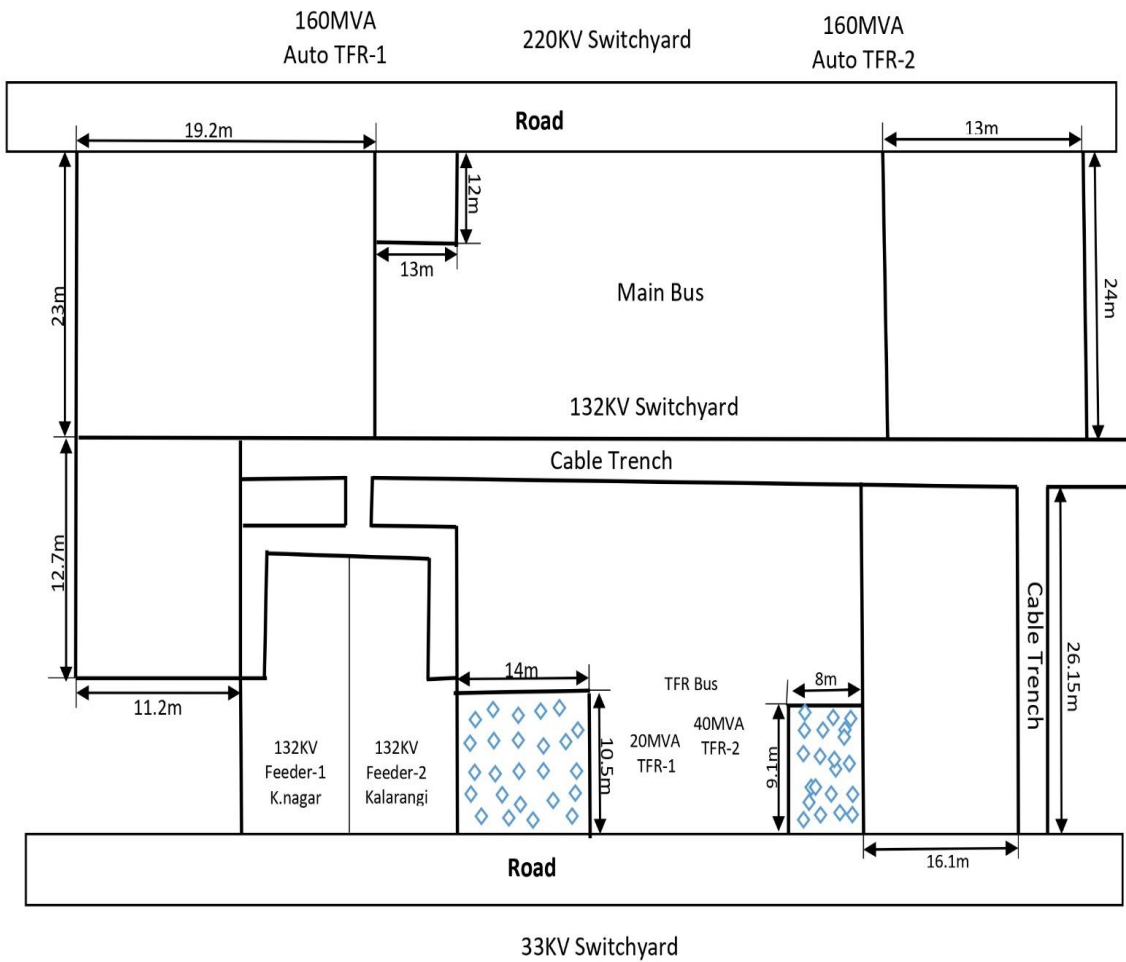

Fig-III (33kV Side Switchyard)

132KV Switchyard



33KV Switchyard

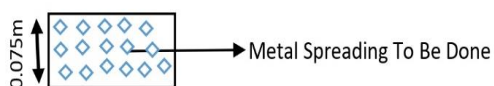
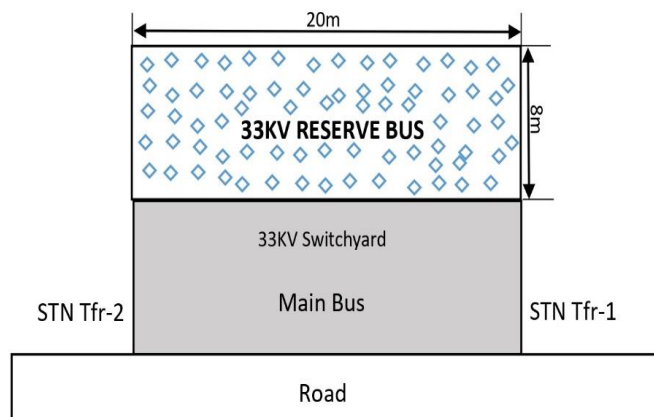

Fig-IV (Layout of Switchyard area for PCC and Metal Spreading)

C. MEASUREMENT

Detail Measurement of PCC area of 220KV,132 KV & 33KV Switchyard of Grid S/S Goda.			
Sl. No	Description of Work	Unit	Length(m)*Breadth(m)
1	33kv side near STN TFR-I&II,Reserve bus	Sqm	444.3
2	132kv cable trench side	Sqm	115.8
3	220kv cable trench side	Sqm	127.2
	Total	Sqm	687.3

Detail Measurement of Metal spreading area of 132 KV & 33KV Switchyard of Grid S/S, Goda.						
Sl. No	Description of Work	Unit	No of Foundation	Length (mtr)	Breadth (mtr)	Quantity
A	132KV Area Gross Total	Sqm				219.88
B	33KV Area Gross Total	Sqm				160.00
C	Deduction of Foundation Area					
1	BPI FOUNDATION	Sqm	7	1.2	1.2	10.08
2	DI &SI FOUNDATION	Sqm	28	0.75	0.75	15.75
3	T8S Column Foundation	Sqm	9	1.7	1.7	26.01
4	T1S Column Foundation	Sqm	1	2.6	2.6	6.76
5	Earth Pit Foundation	Sqm	29	0.75	0.75	16.31
	Deduction (Sub Total C)	Sqm				74.91
D	Net 132KV & 33KV Area Quantity (A-B-C)	Sqm				304.97
	or say	Sqm				305.00

SECTION - IV
Annexure –I

SCHEDULE OF PRICE

Sl. No.	Description of Items (As per Technical Specification)	Unit	Quantity	Unit Rate	Total Price (In Rs.)
1	Earth work in hard soil or gravelly soil within 50m, initial lead and 1.5m, initial lift including rough dressing and breaking clods to maximum 5cm to 7cm and laying in layers not exceeding 0.3m in depth and as per direction of the Engineer-in-charge. This also includes excavation in all type of soils or rocks, back filling and disposal of excess earth or rocks to make the area to a level for construction as per scope and as per approved drawing and specification. Excavation upto 0.125 mm depth.	Cum	85.91		
2	Supply and spreading of sand of loose, fine, clear, good quality river sand, including stacking for measurement with providing and supplying all labour, material, equipments etc. required for proper levelling with water sprinkling.	Cum	34.36		
3	PCC : Spreading of plain cement concert with supply of good quality 20 mm machine broken granite chips, good quality river sand mixing ratio 1:3:6, concreting and maintaining proper sloping for easy discharge of storm water having concrete thickness of 75 mm. including rolling , dressing, compacting, the area and curing . As per technical specification and approved drawing, and as per the instruction of the Engg-in-Charge.	Cum	51.54		
4	Supply and spreading of hard granite stone of 20mm metal, including stacking upto a depth of 75mm thickness.	Cum	22.87		
TOTAL					
Add GST @ 18%					
Grand Total					
Or say					

Schedule of Price

(Rupees.....)
.....) only.

Date

Place

Signature of the Tenderer

with seal.

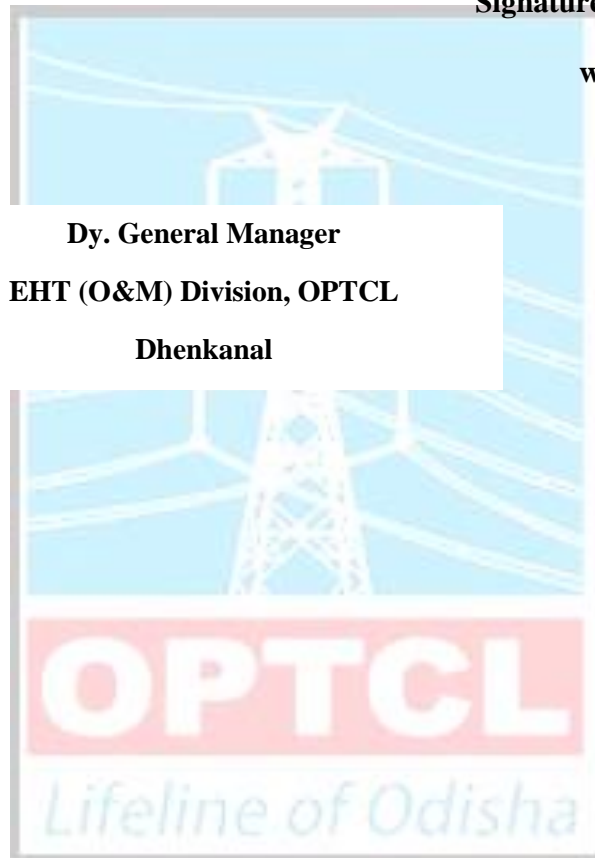

DETAILED DATA SHEET
TO BE FURNISHED BY THE TENDERERS

1	Name of the Agency/ Contractor with detailed Postal Address:	
2	Cost Tender Paper- Rs. 2000/- + 18% GST=Rs.2360/- (Rupees Two thousand three hundred sixty) only	BD/MR No-
3	EMD-Rs.5000.00	BD/MR No-
4	Attested copy of GST Certificate furnished	GST No.....
5	Attested copy of PAN Card	PAN No.....
6	Attested copy of Valid C or D class Civil License	Yes / No
7	Agreed to furnish Contract security deposit	Yes / No
8	Agreed to accept payment terms as per the tender specification	Yes / No
9	Agreed to adhere to completion of work as per the tender specification	Yes / No
10	Agreed to accept penalty clause as per the tender	Yes / No
11	Attach past experience certificate for similar job in OSEB/ GRIDCO/ OPTCL or any other agencies	Yes / No
12	Agreed to keep validity of the offer 03 months from the date of tender opening without any variation in tender clause.	Yes / No
13	Agreed to obtain labour contract license on event of work order from the competent authority	Yes / No

Date

Signature of the Tenderer
with seal